

AIRFLOW



NEXT GENERATION TRAILER AERO TECHNOLOGY



Improves MPG More Than 5%



Durable

*Inset from the edges of the trailer - away from impact areas
Flexible lower chafe strip gives 20" ground clearance*



Lightweight

*Under 120 lbs complete
Half the weight of traditional trailer skirts*



Style

*Modern, refined aerodynamic profile
Enhances the aesthetics of the trailer*



Compliant

*Stand-alone California compliant on reefers
Compliant on dry vans when used with Bumper Bullet*



Safe

*Reduces road spray
Trailer is more stable in crosswinds than with side skirts*



Fast ROI

*Reasonable upfront cost, very low maintenance expense
Can be financed for immediate positive cash flow*

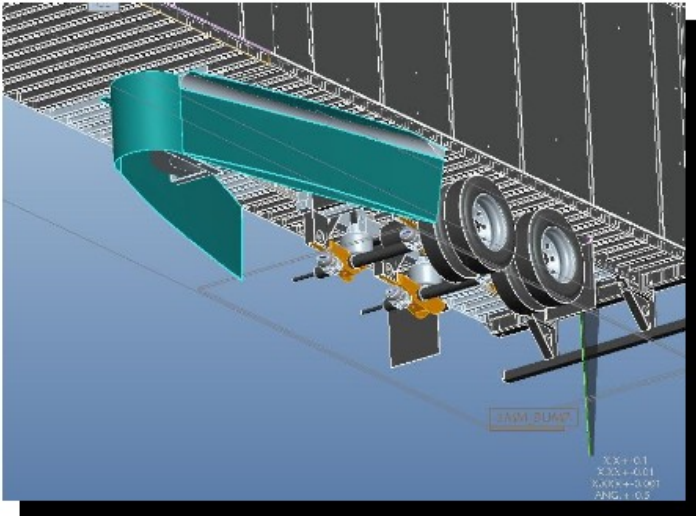

Proudly **MADE IN THE USA** By
DieselMisers, Inc
Rock Hill, SC (877)396-4737
www.dieselmisers.com

For more information, please contact:

